



## The RCA3x Series of 52 mm Gauges Installation and Set Up Instructions

Revision 1

**Contents**

1. Introduction
2. Connecting the Gauge
3. Sensors (Senders)
4. Warnings and Tell-Tales
5. Set Up
6. Fuel Level and Voltage Gauges

## 1. Introduction

Thank you for purchasing your 52 mm gauge from Farrington Instruments. Please read these instructions carefully and ensure that you wire the gauge(s) correctly. These instructions are for the second generation gauges that are fitted with M8 connectors and integral warning LEDs.

## 2. Connecting the Gauge

### WARNING!

The M8 connectors are fragile until mated. Please be careful to align the cable to the instrument avoiding bending the pins on the instrument connector.

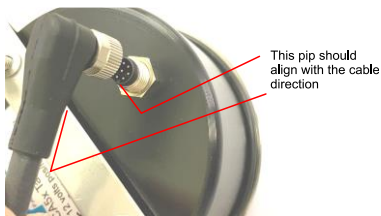

All instruments have the same connector with the same pin-out. Because a pre-wired mating connector is supplied, it is the wire colours that you will use to identify which wire to connect to what. The table below lists the wire functions.

<b>Pin No</b>	<b>Wire Colour</b>	<b>Function</b>
1	White	Ground
2	Brown	Temperature Signal
3	Green	Tell-Tale Enable
4	Yellow	Pressure Signal
5	Grey	+ 5 volts
6	Pink	Pressure Warning
7	Blue	Lighting
8	Red	12 volt Supply

M8 Connector



White

Common Earth Point



Note

Some connectors are marked with 1,2 and 3. 1=A  
2=B and 3=C

Temperature Sensor

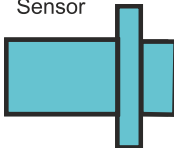

Brown

Tell-Tale Enable

Pressure Warning

Lighting 12v

12v Supply

Green

Pink

Blue

Red

To White

Grey

Yellow



Pressure Sensor

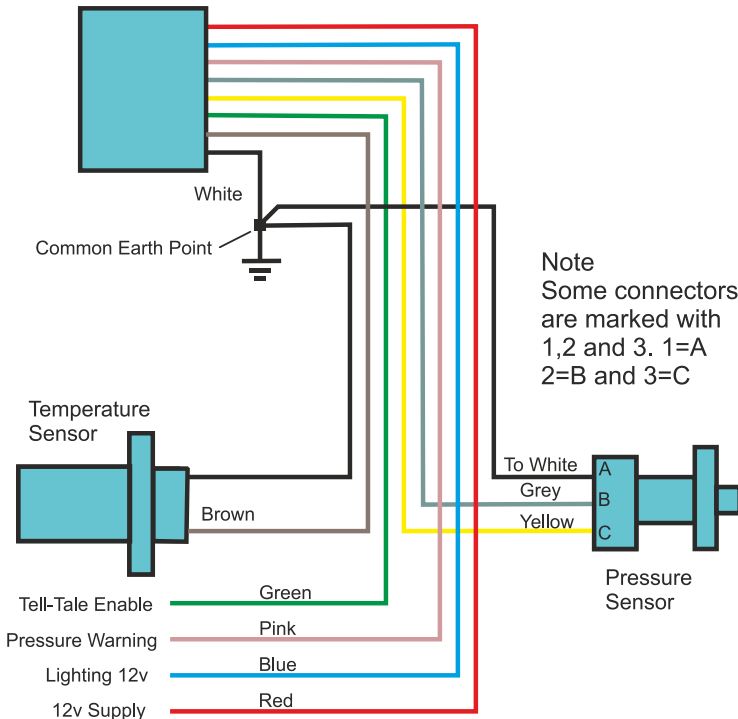

These are the connections for all gauges except fuel level gauges – see Section 6. If the gauge is a pressure gauge, then ignore the wires used for temperature gauges and vice versa – **but be sure to insulate the unused wires.** Of course, you must connect both temperature and pressure wires for dual pressure and temperature gauges.

For Voltage Gauges just connect the power wires white, blue and red.

### White Wire

If you are installing a set of gauges, then connect all the white wires together close to the instruments and then connect this junction to a good earth point near the battery negative with a single wire.

### Brown Wire

Connect this to one side of the temperature sender – it does not matter which. Connect the other side of the temperature sensor to the same point as the white wire.

## Green Wire

This wire should be connected to the tachometer shift 1 wire if, a) you have a Farringdon tachometer and b) if you want to use the minimum pressure tell-tale facility.

## Yellow Wire

The pressure sensor has 3 pins marked A, B and C. (Some sensors have the pins marked 1, 2, 3 where 1 = A, B = 2 and C = 3) Connect the yellow wire to pin C of the pressure sensor. Connect Pin A to the same point as the White ground wire. Connect Pin B to the + 5 volts Grey wire.

## Grey Wire

See above – connect to pressure sensor pin B.

## Pink Wire

This wire pulls to ground through a 100 ohms resistor when the pressure falls below the user set limit. This is suitable to drive an LED but **not** a filament bulb. In order to drive a filament bulb you will need a transistor – contact Farringdon for advice.



## Blue Wire

This should be connected to a 12 volt supply that is turned on with the light switch. A variable or fixed resistor can be fitted between the supply and the blue wire to allow you to alter the level of illumination.

## Red Wire

This should be connected a 12 volt supply which is switched by the master switch or ignition switch. Connecting it to a supply switched on with the master switch will enable the gauges to go through their set up procedure before starting the engine.

## Orientation of the M8 Connector

The M8 connector with the moulded lead is a right angle type which minimises the space taken up behind the instrument but may not be oriented to direct the cable in the direction required. It can be rotated as follows:

Connect the moulded connector with the flying lead. Then loosen the M8 nut securing the fixed connector to the instrument a few turns. It will now be possible to rotate the connector – BUT DO NOT rotate the connector more than 180 degrees either to the left or right. Once the correct angle is found, tighten the nut again. This nut compresses an O ring on the inner face of the enclosure – be careful not to over-tighten.



### 3. Sensors (Senders)

The Bosch temperature sensor has a M12 x 1.5 thread but is supplied with an adapter that connects to the 3/8 BSP threaded fitting used for most capillary fittings. A connector is supplied for these sensors. Note that it does not matter which way round this sensor is connected. However, please connect the ground wire to the same point as the white ground supply wire.

The pressure Sensor has two very small holes in the plastic part that allows air into the sensor so that gauge pressure is measured. Please mount and protect the sensors so that water cannot enter the sensors via these holes but **DO NOT seal them**. A Metripack connector is supplied that plugs onto the pressure sensor. These are difficult to wire without the proper crimping tools – please ask if you would prefer a pre-wired connector.

#### Warnings and Tell-Tales

Both pressure and temperature single gauges and the dual gauges have warning LEDs behind the dials which light when the temperature goes higher than the set warning temperature or the pressure is lower than the set warning pressure. These warnings are independent of the position of the gauge needle and should not be ignored.

The temperature gauges have a tell-tale system whereby the highest temperature measured by the gauge is stored in the internal memory. When the gauge is powered up the hand is driven against the internal stop at the bottom of the scale and then the hand is driven to the current maximum temperature tell-tale where it remains for one second. Finally, the hand is driven to the top of the scale (as a check of the mechanical system) before being driven to the current temperature.

Pressure gauges provide the same system for minimum pressure when the Warning Enable wire is connected to the Shift Light 1 wire from a Farrington Tachometer. The minimum pressure is recorded if the engine is going over the Shift 1 setting.

## 4. Set Up

The Farrington 52 mm gauges use a novel method of setting up the warning levels. In all gauges there is a magnetic field sensor which responds to a powerful magnet fitted to the end of the set up wand supplied with all sets of gauges.

### **Set Up Procedure**

1. Start with the power turned off.
2. Hold the magnetic end of the wand up against the gauge at approximately the 1 o'clock position.
3. Turn on the power.
4. The gauge will show the pre-set minimum warning pressure or the maximum warning temperature.
5. Move the wand away from the instrument.
6. The hand will start slowly moving down the temperature scale or up the pressure scale. When the hand has reached the desired warning reading, put the magnetic end of the wand back on the glass at the 1 o'clock position. This will stop the movement.

7. Remove the wand from the glass. For single gauges, this ends the set up procedure and the gauge will go through its normal power up sequence. For dual gauges, the pressure gauge will start at step 6.

### **Resetting Tell-Tales**

The tell-tales are reset by placing the magnetic wand at the 1 o'clock position on the instrument glass. This can be done at any time while the instrument is powered.

## 5. Fuel Level Gauges

Farrington make both single and dual fuel level gauges. At present these use VDO float sensors only. For single gauges, the sensor should be connected to the temperature signal pin (brown wire) and ground. For dual gauges the other sensor, the right hand tank, should be connected to the pressure signal (yellow wire).

The blue LED warning lights can be set in the same way as other warning except for the case of a dual level gauge where the magnetic setup wand has to be held over the 40% mark on the right hand gauge. If you do not want warning lights, then set the warning levels below the 5% mark.

Farringdon Instruments Limited – The Old Stables – Manor  
Farm – West Worldham – Alton – Hampshire GU34 3BD

[www.farringdoninstruments.com](http://www.farringdoninstruments.com)  
[email@farringdoninstruments.com](mailto:email@farringdoninstruments.com)

Telephone +44 (0) 1420 541 591